

## Positive-Voltage Regulators

### Features

- Output Current of 150mA
- Thermal Overload Protection
- Short Circuit Protection
- Output transistor safe area protection
- No external components
- Package: SOT23, SOT89-3 and TO92

### General Description

TX78LXX-AV is three-terminal positive regulators. One of these regulators can deliver up to 150 mA of output current. The internal limiting and thermal-shutdown features of the regulator make them essentially immune to overload. When used as a

replacement for a zener diode-resistor combination, an effective improvement in output impedance can be obtained, together with lower quiescent current.

### Selection Table

Part No.	Output Voltage	Package	Marking
TX78L33-XXX-AV	3.3V	SOT23 SOT89-3 TO92	78L33/TXxxx
TX78L05-XXX-AV	5.0V		78L05/TXxxx
TX78L06-XXX-AV	6.0V		78L06/TXxxx
TX78L08-XXX-AV	8.0V		78L08/TXxxx
TX78L09-XXX-AV	9.0V		78L09/TXxxx
TX78L12-XXX-AV	12.0V		78L12/TXxxx
TX78L15-XXX-AV	15.0V		78L15/TXxxx
TX78L18-XXX-AV	18.0V		78L18/TXxxx
TX78L24-XXX-AV	24.0V		78L24/TXxxx

### Order Information

#### TX78L①②-③④⑤-AV

Designator	Symbol	Description
① ②	Integer	Output Voltage(3.3~24.0V)
③	1	Tolerance :1%
	2	Tolerance :2%
④	N	Package: SOT23
	P	Package: SOT89-3
	T	Package: TO92
⑤	R	RoHS / Pb Free
	G	Halogen Free

### Block Diagram

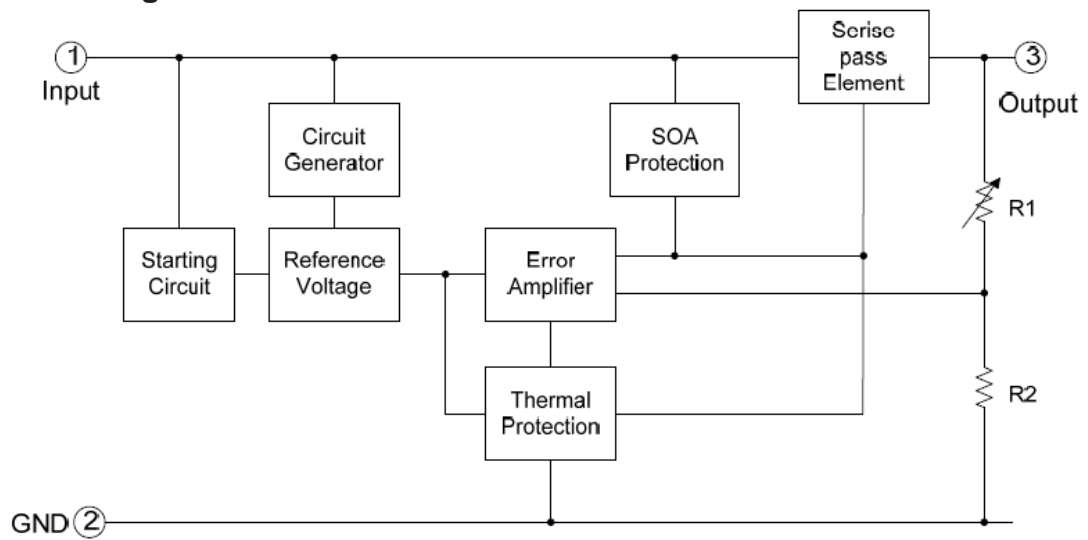

### Pin Configuration

SOT23 (Top View)

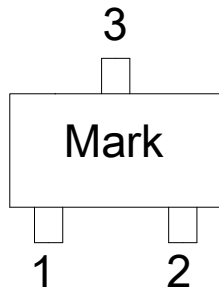

Table1: TX78LXX series (SOT23 PKG)

PIN NO.	PIN NAME	FUNCTION
1	VOUT	Output voltage pin
2	VIN	Input voltage pin
3	GND	GND pin

SOT89 (Top View)

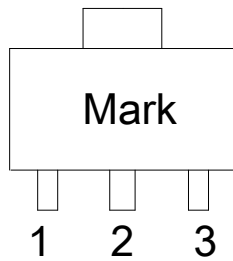

Table2: TX78LXX series (SOT89-3 PKG)

PIN NO.	PIN NAME	FUNCTION
1	VOUT	Output voltage pin
2	GND	GND pin
3	VIN	Input voltage pin

TO92 (Top View)

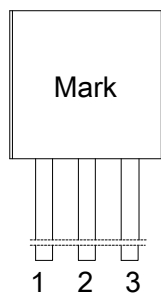

Table3: TX78LXX series (TO92 PKG)

PIN NO.	PIN NAME	FUNCTION
1	VOUT	Output voltage pin
2	GND	GND pin
3	VIN	Input voltage pin

## **TX78LXX-AV**

### **Positive-Voltage Regulators**

---

#### **Absolute Maximum Ratings (Ta=25°C)**

<b>Parameter</b>		<b>Rating</b>	<b>Unit</b>
Input supply voltage: VIN MAX		35	V
Output current: Iout MAX		150	mA
MAX Power: Pmax	SOT23	0.2	W
	SOT89	0.5	W
	TO92	0.5	W
Junction temperature: Tj		-55~150	°C
Operation temperature: Topr		-40~125	°C
Storage temperature: Tstr		-55~150	°C
Soldering temperature and time		+260(Recommended 10S)	°C
ESD Rating, (HBM)		5	KV

Note: The absolute maximum ratings are rated values exceeding which the product could suffer physical damage. These values must therefore not be exceeded under any conditions.

## TX78LXX-AV

### Positive-Voltage Regulators

#### Electrical Characteristics

TX78L05 (C<sub>in</sub>=0.33uF, C<sub>o</sub>=0.1uF, T<sub>a</sub>=25°C, unless otherwise noted)

Parameter	Symbol	Conditions	Min.	Typ.	Max.	Unit	
Output Voltage	V <sub>out</sub>	I <sub>o</sub> =40mA, V <sub>IN</sub> =10V	1%	4.975	5.025	5.075	V
			2%	4.925	5.025	5.125	
		I <sub>o</sub> =1mA~40mA V <sub>IN</sub> =7V~18V		4.925	5.025	5.125	
		I <sub>o</sub> =1mA~10mA V <sub>IN</sub> =10V		4.925	5.025	5.125	
Line Regulation	LNR	V <sub>IN</sub> =7V~18V, I <sub>o</sub> =20mA	-20	-	20	mV	
Load Regulation	LDR	V <sub>IN</sub> =10V, I <sub>o</sub> =1mA~100mA	-50	-	50	mV	
		V <sub>IN</sub> =10V, I <sub>o</sub> =1mA~40mA	-30	-	30		
Dropout Voltage	V <sub>DIF</sub>	T <sub>a</sub> =25°C, I <sub>o</sub> =100mA	-	2	-	V	
Ripple Rejection	PSRR	T <sub>a</sub> =25°C, f=120Hz, I <sub>o</sub> =10mA, V <sub>IN</sub> =8V	-	70	-	dB	
Output noise Voltage	V <sub>N</sub>	F=10Hz to 100KHz	-	40	-	uV/V <sub>o</sub>	
Quiescent Current	I <sub>q</sub>	V <sub>IN</sub> =10V, I <sub>O</sub> UT=40mA	-	1.7	-	mA	
Quiescent Current Change	ΔI <sub>q</sub>	V <sub>IN</sub> =8V~20V, I <sub>o</sub> =1mA	-1.5	-	1.5	mA	
		V <sub>IN</sub> =10V, I <sub>O</sub> UT=1mA~40mA	-1	-	1		

LNR: Line Regulation. The change in output voltage for a change in the input voltage. The measurement is made under conditions of low dissipation or by using pulse techniques such that the average chip temperature is not significantly affected.

LDR: Load Regulation. The change in output voltage for a change in load current at constant chip temperature.

## TX78LXX-AV

### Positive-Voltage Regulators

TX78L06 (Cin=0.33uF, Co=0.1uF, Ta=25°C, unless otherwise noted)

Parameter	Symbol	Conditions	Min.	Typ.	Max.	Unit	
Output Voltage	Vout	Io=40mA, VIN=11V	1%	5.964	6.025	6.085	V
			2%	5.904	6.025	6.145	
		Io=1mA~40mA VIN=8V~20V		5.904	6.025	6.145	
		Io=1mA~10mA VIN=11V		5.904	6.025	6.145	
Line Regulation	LNR	VIN=8V~20V, Io=20mA	-30	-	30	mV	
Load Regulation	LDR	VIN=11V, Io=1mA~100mA	-60	-	60	mV	
		VIN=11V, Io=1mA~40mA	-40	-	40		
Dropout Voltage	V <sub>DIF</sub>	Ta=25°C, Io=100mA	-	2	-	V	
Ripple Rejection	PSRR	Ta=25°C, f=120Hz, Io=10mA, VIN=9V	-	70	-	dB	
Output noise Voltage	V <sub>N</sub>	F=10Hz to 100KHz	-	40	-	uV/Vo	
Quiescent Current	I <sub>Q</sub>	VIN=11V, IOU=40mA	-	1.7	-	mA	
Quiescent Current Change	ΔI <sub>Q</sub>	VIN=9V~20V, Io=1mA	-1.5	-	1.5	mA	
		VIN=11V, IOU=1mA~40mA	-1	-	1		

LNR: Line Regulation. The change in output voltage for a change in the input voltage. The measurement is made under conditions of low dissipation or by using pulse techniques such that the average chip temperature is not significantly affected.

LDR: Load Regulation. The change in output voltage for a change in load current at constant chip temperature.

## TX78LXX-AV

### Positive-Voltage Regulators

TX78L08 (Cin=0.33uF, Co=0.1uF, Ta=25°C, unless otherwise noted)

Parameter	Symbol	Conditions	Min.	Typ.	Max.	Unit	
Output Voltage	Vout	Io=40mA, VIN=13V	1%	7.945	8.025	8.105	V
			2%	7.864	8.025	8.185	
		Io=1mA~40mA VIN=10V~23V		7.864	8.025	8.185	
		Io=1mA~10mA VIN=13V		7.864	8.025	8.185	
Line Regulation	LNR	VIN=10V~23V, Io=20mA	-40	-	40	mV	
Load Regulation	LDR	VIN=13V, Io=1mA~100mA	-65	-	65	mV	
		VIN=13V, Io=1mA~40mA	-45	-	45		
Dropout Voltage	V <sub>DIF</sub>	Ta=25°C, Io=100mA	-	2	-	V	
Ripple Rejection	PSRR	Ta=25°C, f=120Hz, Io=10mA, VIN=11V	-	70	-	dB	
Output noise Voltage	V <sub>N</sub>	F=10Hz to 100KHz	-	40	-	uV/Vo	
Quiescent Current	I <sub>Q</sub>	VIN=13V, IOU <sub>T</sub> =40mA	-	1.7	-	mA	
Quiescent Current Change	ΔI <sub>Q</sub>	VIN=11V~23V, Io=1mA	-1.5	-	1.5	mA	
		VIN=13V, IOU <sub>T</sub> =1mA~40mA	-1	-	1		

LNR: Line Regulation. The change in output voltage for a change in the input voltage. The measurement is made under conditions of low dissipation or by using pulse techniques such that the average chip temperature is not significantly affected.

LDR: Load Regulation. The change in output voltage for a change in load current at constant chip temperature.

## TX78LXX-AV

### Positive-Voltage Regulators

TX78L12 (Cin=0.33uF, Co=0.1uF, Ta=25°C, unless otherwise noted)

Parameter	Symbol	Conditions	Min.	Typ.	Max.	Unit	
Output Voltage	Vout	Io=40mA, VIN=17V	1%	11.904	12.025	12.145	V
			2%	11.784	12.025	12.265	
		Io=1mA~40mA VIN=14V~27V		11.784	12.025	12.265	
		Io=1mA~10mA VIN=17V		11.784	12.025	12.265	
Line Regulation	LNR	VIN=14V~27V, Io=20mA	-50	-	50	mV	
Load Regulation	LDR	VIN=17V, Io=1mA~100mA	-70	-	70	mV	
		VIN=17V, Io=1mA~40mA	-50	-	50		
Dropout Voltage	V <sub>DIF</sub>	Ta=25°C, Io=100mA	-	2	-	V	
Ripple Rejection	PSRR	Ta=25°C, f=120Hz, Io=10mA, VIN=17V	-	70	-	dB	
Output noise Voltage	V <sub>N</sub>	F=10Hz to 100KHz	-	40	-	uV/Vo	
Quiescent Current	I <sub>Q</sub>	VIN=17V, IOU <sub>T</sub> =40mA	-	1.7	-	mA	
Quiescent Current Change	ΔI <sub>Q</sub>	VIN=14V~27V, Io=1mA	-1.5	-	1.5	mA	
		VIN=17V, IOU <sub>T</sub> =1mA~40mA	-1	-	1		

LNR: Line Regulation. The change in output voltage for a change in the input voltage. The measurement is made under conditions of low dissipation or by using pulse techniques such that the average chip temperature is not significantly affected.

LDR: Load Regulation. The change in output voltage for a change in load current at constant chip temperature.



## Positive-Voltage Regulators

### Typical Performance Characteristics

TX78L05 (Note:  $C_{IN}=0.33\mu F$ ,  $C_{OUT}=0.1\mu F$ ,  $T=25^\circ C$ , unless specified otherwise)

(1) Quiescent Current VS Input Voltage

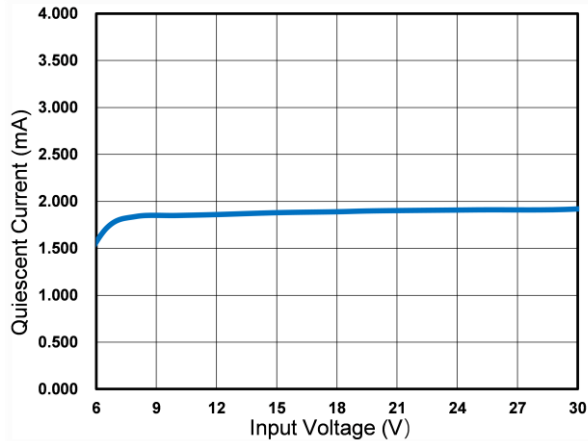

(2) Output Voltage VS Input Voltage

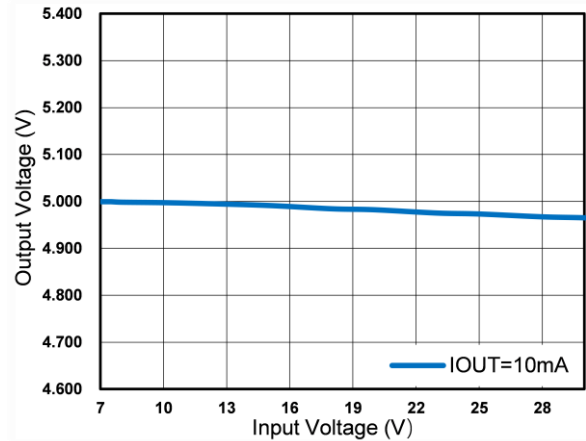

(3) Output Voltage VS Output Current

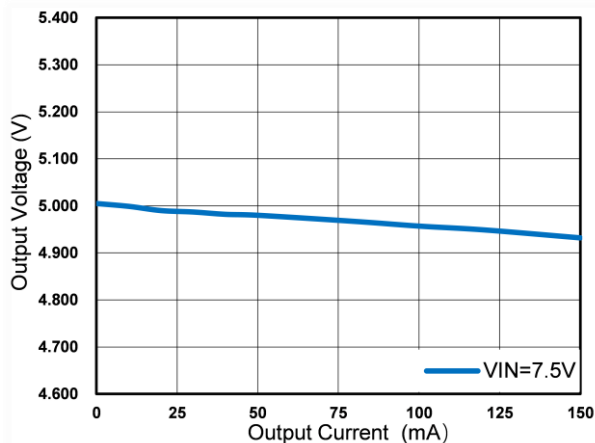

(4) Short-Circuit Current VS Input Voltage

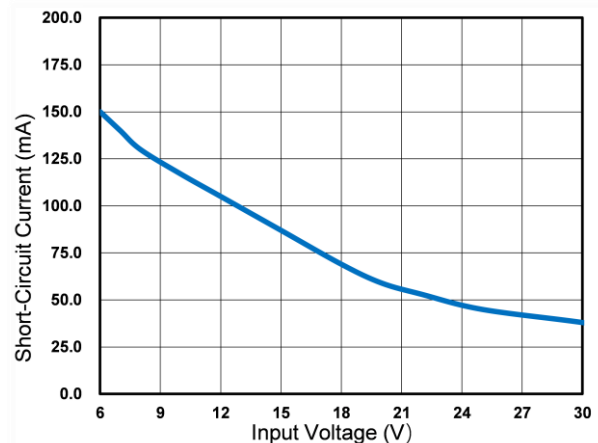

(5) Dropout Voltage VS Output Current

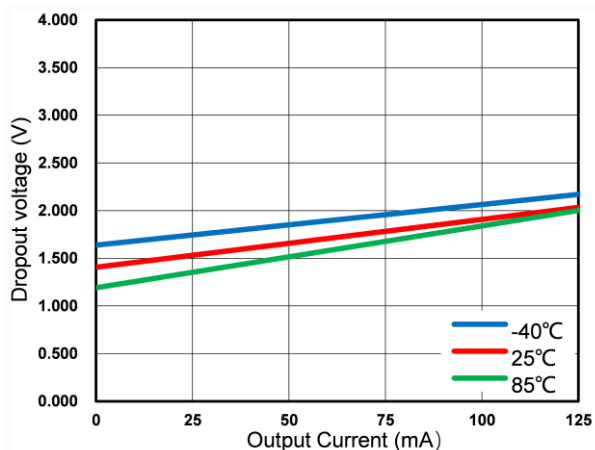

(6) Dropout Voltage VS Temperature

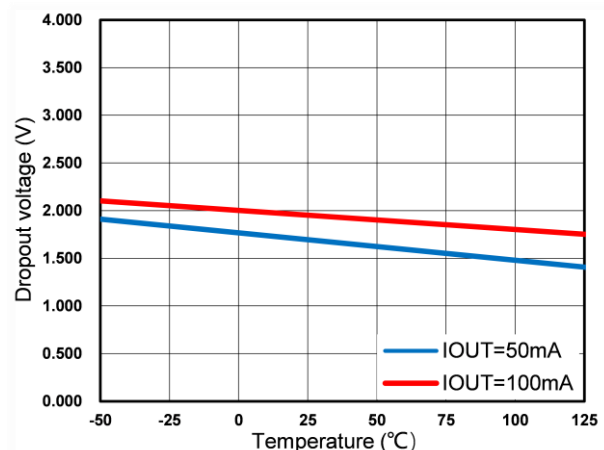

# TX78LXX-AV

## Positive-Voltage Regulators

(7) Quiescent Current VS Temperature

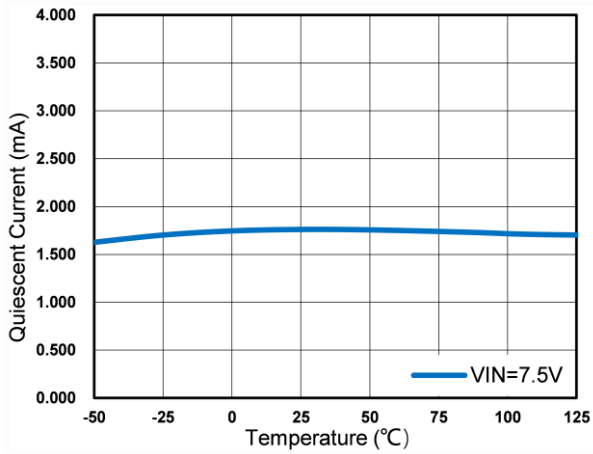

(8) Output Voltage VS Temperature

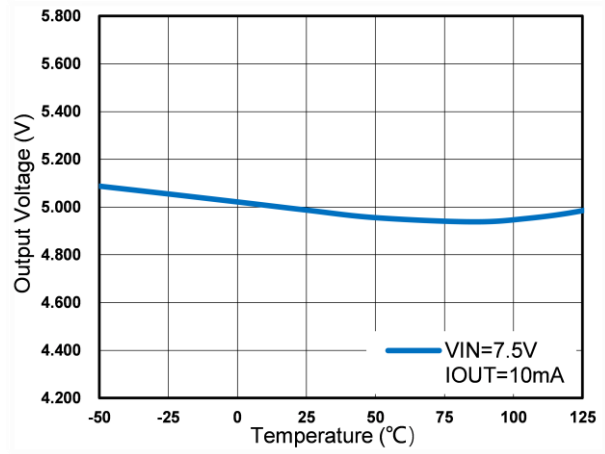

(9) Line Regulation VS Temperature

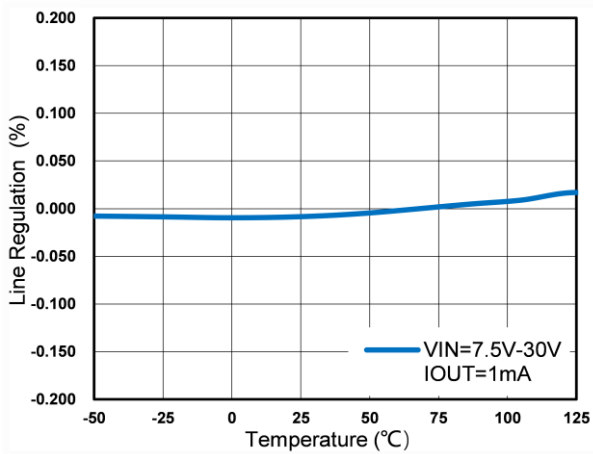

(10) Load Regulation VS Temperature

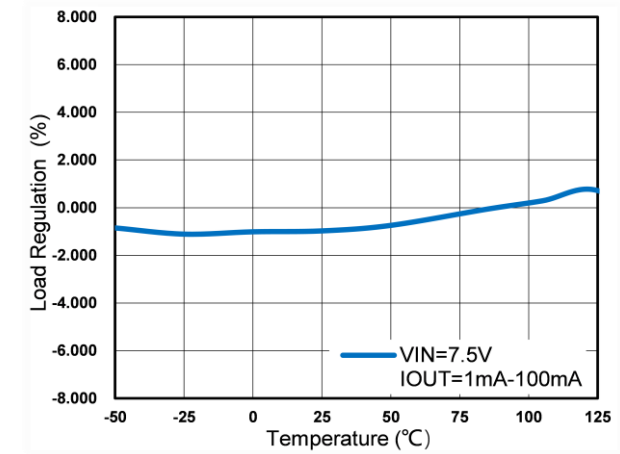

(11) Output Voltage VS Temperature

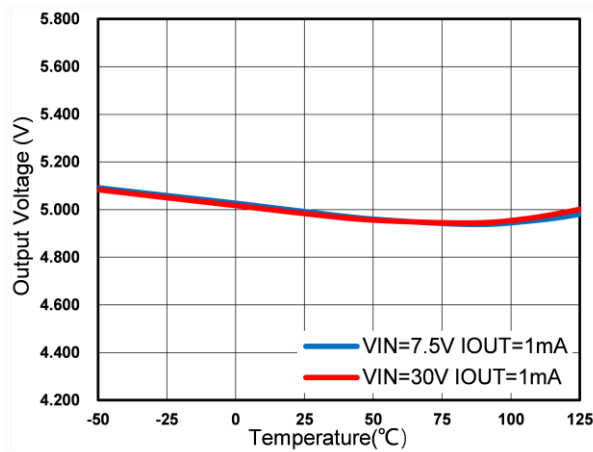

(12) Output Voltage VS Temperature

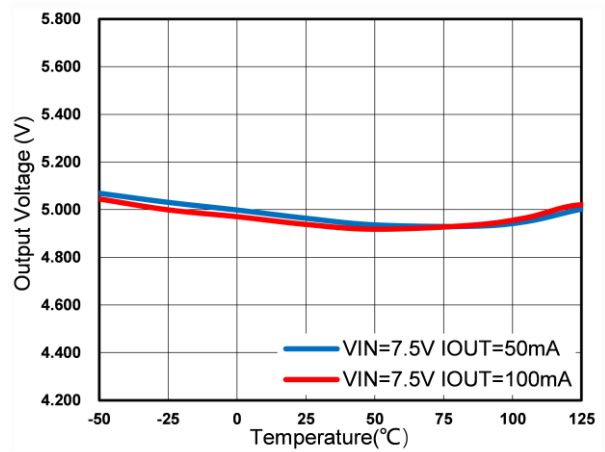

## TX78LXX-AV

### Positive-Voltage Regulators

---

(13) Short-Current VS Temperature

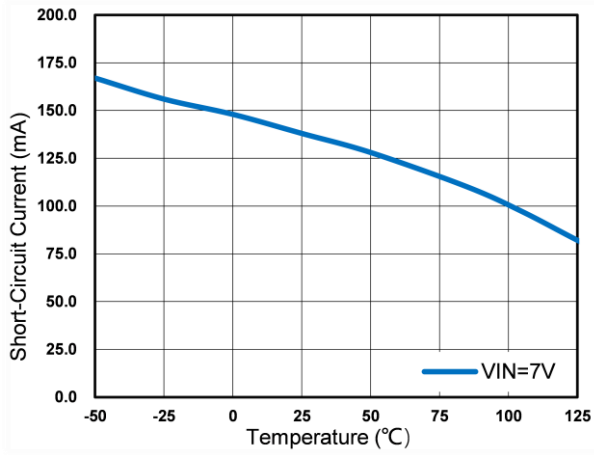

(14) PSRR

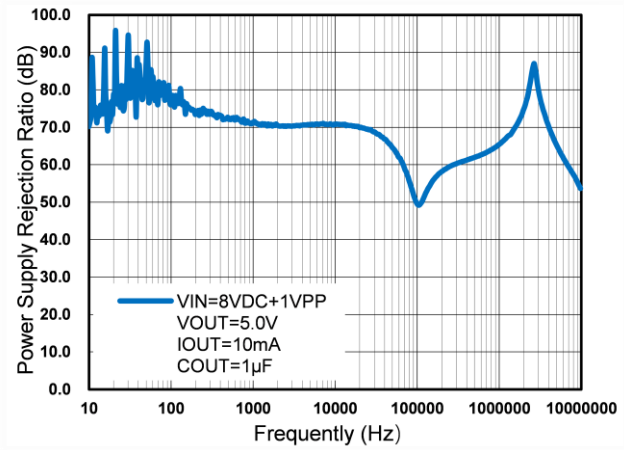

# TX78LXX-AV

## Positive-Voltage Regulators

(15) Input Transient Response ( $V_{IN}=8V-12V$ )

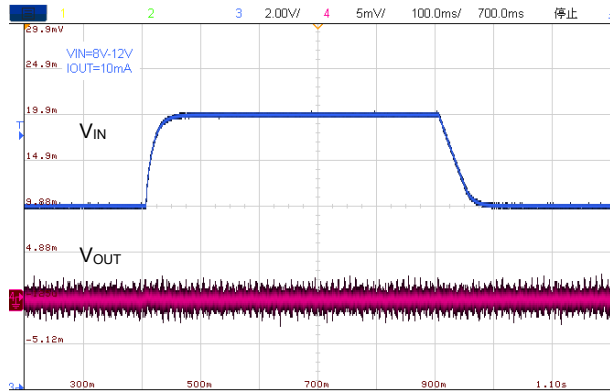

(16) Input Transient Response ( $V_{IN}=8V-30V$ )

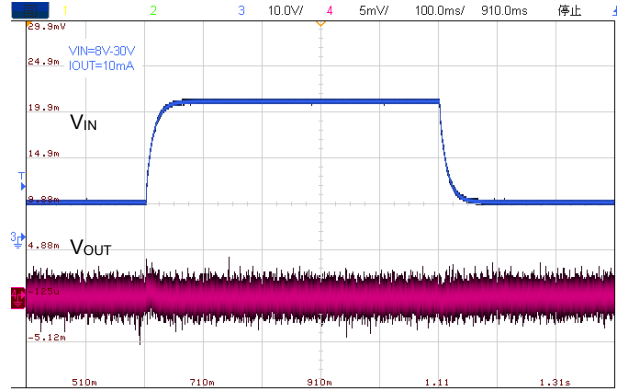

(17) Load Transient Response ( $I_{OUT}=1mA-150mA$ )

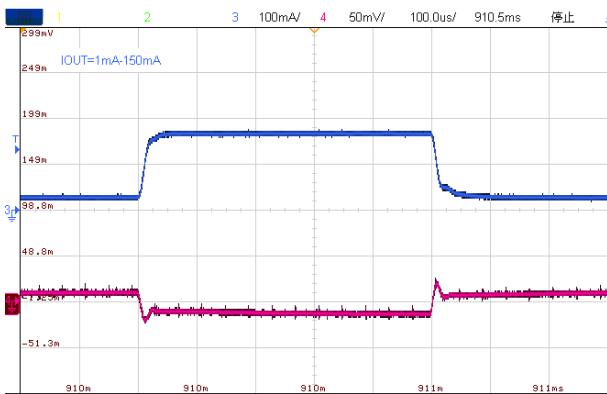

(18) Load Transient Response ( $I_{OUT}=50mA-150mA$ )

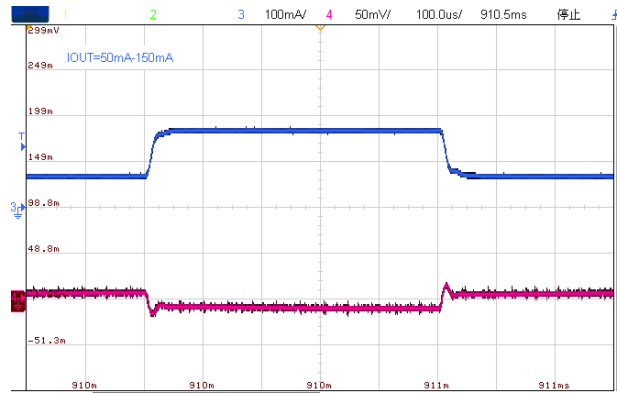

(19) Power ON

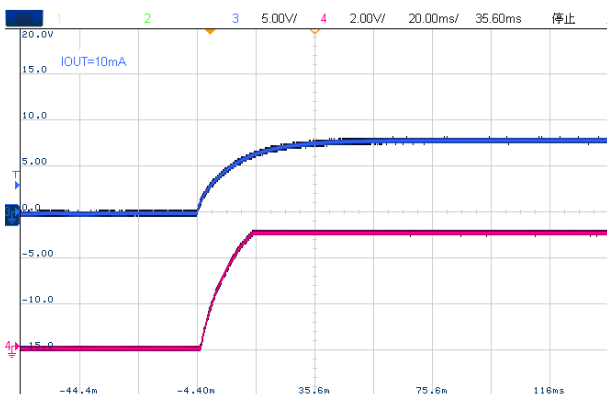

(20) Power OFF

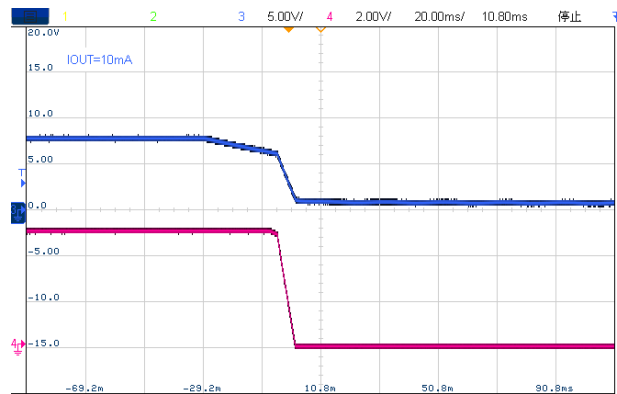

## Positive-Voltage Regulators

### Operation Description

TX78LXX-AV is designed with Thermal Overload Protection that shuts down the circuit when subjected to an excessive power overload condition, and Output Transistor Safe-Area Compensation that reduces the output short circuit current as the voltage across the pass transistor is increased.

In many low current applications, compensation capacitors are not required. However, it is recommended that the regulator input be bypassed with a capacitor if the regulator is connected to the power supply filter with long wire lengths, or if the output load capacitance is large. An input bypass capacitor should be selected to provide good high frequency characteristics to insure stable operation under all load conditions. A 0.33 $\mu$ F or larger tantalum, mylar, or other capacitor having low internal impedance at high frequencies should be chosen. The bypass capacitor should be mounted with the shortest possible leads directly across the regulator's input terminals. Normally good construction techniques should be used to minimize ground loops and lead resistance drops since the regulator has no external sense lead.

### Typical Application

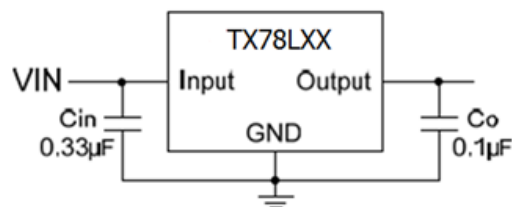

Fig.1 Typical Application

A common ground is required between the input and the output voltages. The input voltage must remain typically 2.0 V above the output voltage even during the low point on the input ripple voltage.

Cin is required if regulator is located an appreciable distance from power supply filter.

Co is not needed for stability, however, it does improve transient response.

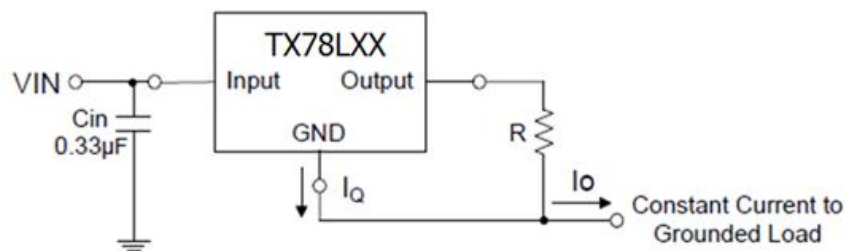

Fig.2 Constant Current Regulator

## Positive-Voltage Regulators

### Package Information

#### 3-pin SOT23 Outline Dimensions

Symbol	Dimensions In Millimeters		Dimensions In Inches	
	Min.	Max.	Min.	Max.
A	0.900	1.150	0.035	0.045
A1	0.000	0.100	0.000	0.004
A2	0.900	1.050	0.035	0.041
b	0.300	0.500	0.012	0.020
c	0.080	0.150	0.003	0.006
D	2.800	3.000	0.110	0.118
E	1.200	1.400	0.047	0.055
E1	2.250	2.550	0.089	0.100
e	0.950 TYP.		0.037 TYP.	
e1	1.800	2.000	0.071	0.079
L	0.550 REF.		0.022 REF.	
L1	0.300	0.500	0.012	0.020
$\theta$	0°	8°	0°	8°

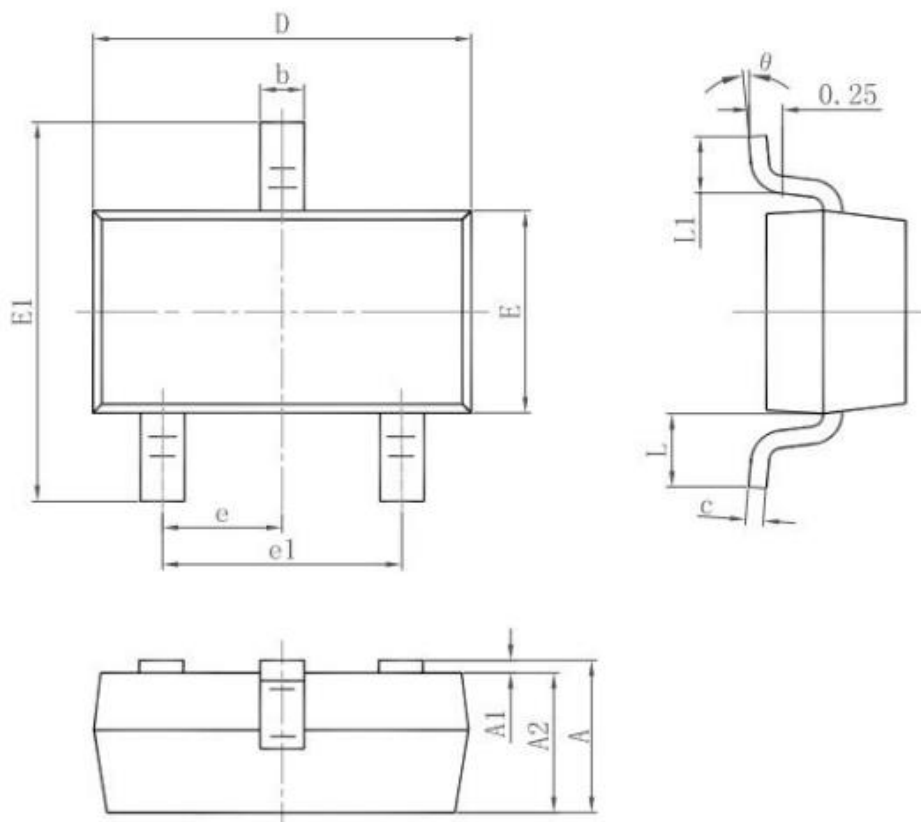

**Positive-Voltage Regulators**

**3-pin SOT89-3 Outline Dimensions**

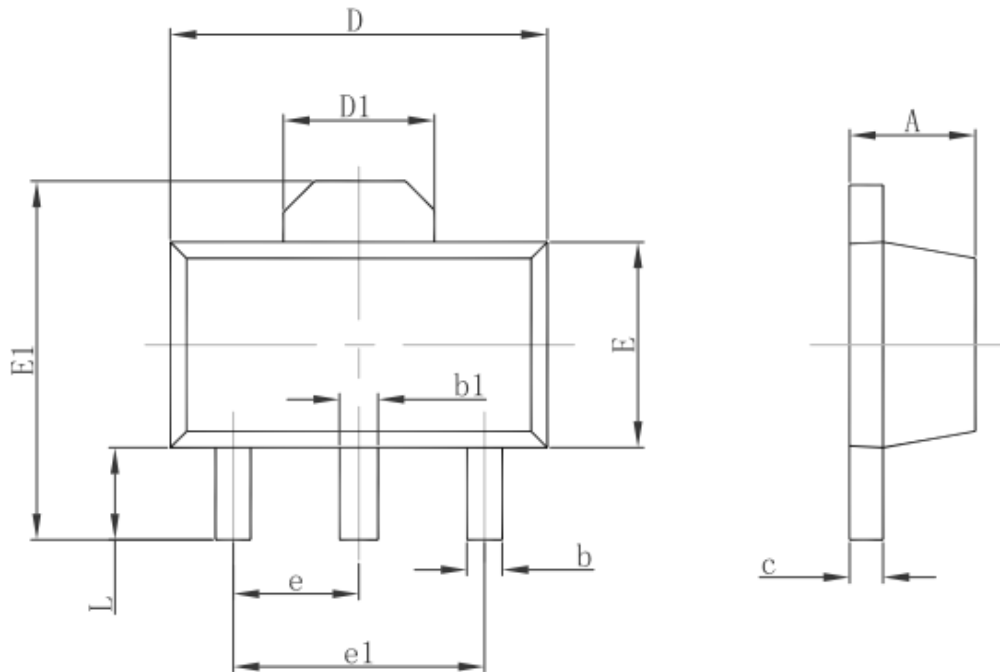

Symbol	Dimensions In Millimeters		Dimensions In Inches	
	Min.	Max.	Min.	Max.
A	1.400	1.600	0.055	0.063
b	0.320	0.520	0.013	0.020
b1	0.400	0.580	0.016	0.023
c	0.350	0.440	0.014	0.017
D	4.400	4.600	0.173	0.181
D1	1.550 REF.		0.061 REF.	
E	2.300	2.600	0.091	0.102
E1	3.940	4.250	0.155	0.167
e	1.500 TYP.		0.060 TYP.	
e1	3.000 TYP.		0.118 TYP.	
L	0.900	1.200	0.035	0.047

## TX78LXX-AV

### Positive-Voltage Regulators

---

#### 3-pin TO92 Outline Dimensions

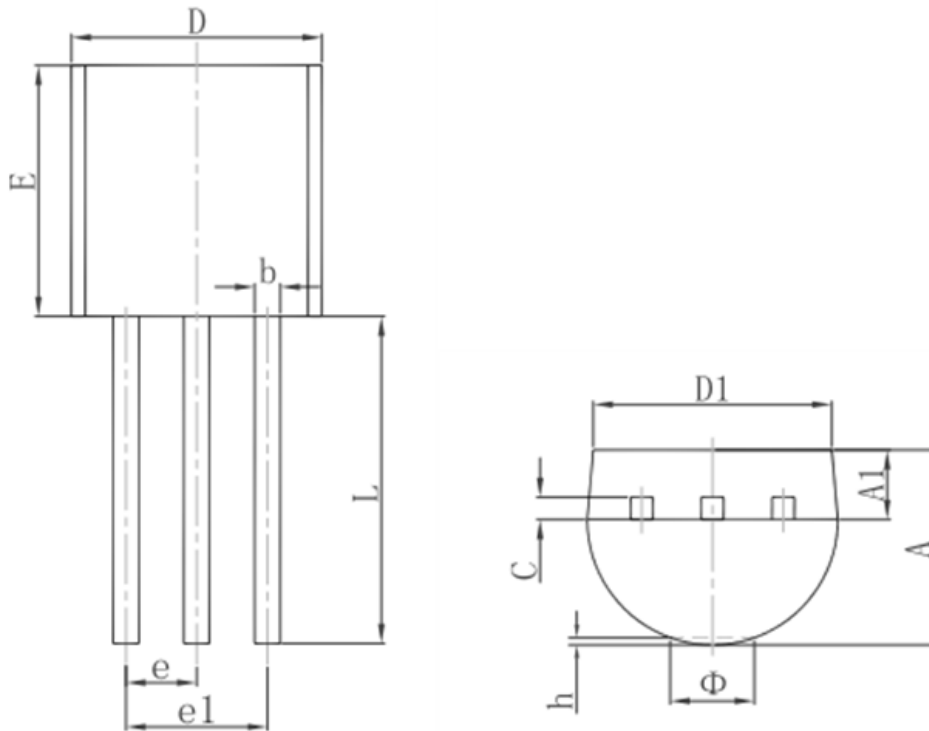

Symbol	Dimensions In Millimeters		Dimensions In Inches	
	Min.	Max.	Min.	Max.
A	3.300	3.700	0.130	0.146
A1	1.100	1.400	0.043	0.055
b	0.380	0.550	0.015	0.022
c	0.360	0.510	0.014	0.020
D	4.300	4.700	0.169	0.185
D1	3.430		0.135	
E	4.300	4.700	0.169	0.185
e	1.270 TYP.		0.050 TYP.	
e1	2.440	2.640	0.096	0.104
L	14.100	14.500	0.555	0.571
Φ		1.600		0.063
h	0.000	0.380	0.000	0.015